

## TECHNICAL SPECIFICATIONS

	PARAMETERS	MEASUREMENTS
BODY DIMENSIONS	LENGTH	2020 mm
	WIDTH	785 mm
	HEIGHT	1103 mm
	WHEEL BASE	1285 mm
	GROUND CLEARANCE	160 mm
	KERB WEIGHT	116 kg
	SEAT HEIGHT	790 mm
	FUEL TANK CAPACITY	11.2 L
ENGINE	TYPE	4 Stroke, SI Engine
	DISPLACEMENT	123.94cc
	MAX NET POWER	8 Kw @ 7500 rpm
	MAX NET TORQUE	10.9 N-m @ 6000 rpm
	FUEL SYSTEM	PGM- FI
	BORE X STROKE	50.0 X 63.1 mm
	COMPRESSION RATIO	10.0 : 1
	STARTING METHOD	Self / Kick
TRANSMISSION	CLUTCH TYPE	Multiplate Wet Clutch
	NO. OF GEARS	5 Gear
TYRES & BRAKES	TYRE SIZE & TYPE (FRONT)	80/100-18 M/C 47P, Tubeless
	TYRE SIZE & TYPE (REAR)	100/80-18 M/C 53P, Tubeless
	BRAKE TYPE & SIZE (FRONT)	Disc 240 mm, Drum 130 mm
	BRAKE TYPE & SIZE (REAR)	Drum 130 mm
FRAME & SUSPENSION	FRAME TYPE	Diamond Type
	FRONT SUSPENSION	Telescopic
	REAR SUSPENSION	Hydraulic Type
ELECTRICALS	BATTERY	12 V, 4.0 Ah
	HEAD LAMP	LED, DC

- \*The technical specifications and design of the vehicle may vary according to the requirements and conditions without any notice.
- \*Distance to empty, real-time and average mileage readings may vary as per variant and riding conditions.
- SP125 meets Bharat Stage VI norms.
- Product shown in the picture may vary from the actual product available in the market.
- Accessories shown in the picture are not part of standard equipment.

Honda Motorcycle and Scooter India Pvt. Ltd.

Registered Office: Plot No.1, Sector-03, IMT Manesar, Distt. Gurugram-122050 (Haryana)

Tel: +91(0)124-2290011, +91(0)6712800, Fax: +91(0)124-6712999

Visit us at: [www.honda2wheelersindia.com](http://www.honda2wheelersindia.com) Customer Care: [customercare@honda2wheelersindia.com](mailto:customercare@honda2wheelersindia.com)



PEARL  
SIREN BLUE



IMPERIAL RED  
METALLIC



MATTE AXIS  
GRAY METALLIC



BLACK



MATTE MARVEL  
BLUE METALLIC

Dealer Stamp

**Devaashva Honda**

Honda 2 Wheeler Showroom,  
Jalna

Tel: 8888866256

Mob: 8888801607

BOOK ONLINE NOW!  
[www.honda2wheelersindia.com](http://www.honda2wheelersindia.com)



**SP125**  
**BEYOND  
ADVANCED**

CELEBRATING  
**25 LAKHS**  
AND COUNTING

Experience the thrilling performance of the new SP125, that comes with exciting advanced features. Advanced traction with wider rear tyre ensures better braking. Advanced look makes sure you grab eyeballs as you go. And the advanced display keeps you ahead, always. When they come together, you get a ride that's beyond anything you've experienced before. A ride that's beyond advanced.

### ADVANCED LOOK

WITH NEW-AGE GRAPHICS



### ADVANCED TRACTION

WITH WIDER TYRE

**SP125**  
**BEYOND**  
**ADVANCED**

## ADVANCED DISPLAY



REAL-TIME  
MILEAGE



DISTANCE  
TO EMPTY



AVERAGE  
MILEAGE

# ADVANCED **TECHNOLOGY**

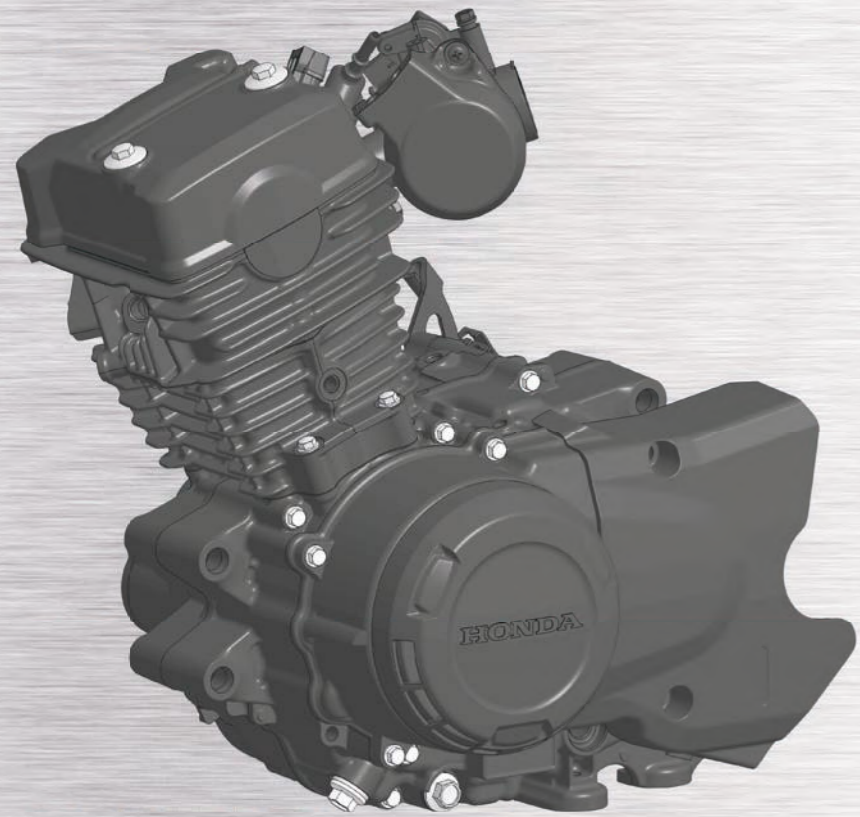

## **125cc BS-VI ENGINE**

The latest innovation in the engine is ahead of its time.  
The intelligent engine contributes to a cleaner environment while delivering unmatched performance.

### **eSP**

With SP125, expect nothing but the best. Honda's Enhanced Smart Power (eSP) technology maximises performance and mileage by reducing friction. The ACG starter integrated with eSP technology starts the engine quietly giving you the best of riding experience and technology.

### **SILENT START WITH ACG**

Honda's unique ACG starter motor removes gear meshing noise and helps start the engine without a jolt.

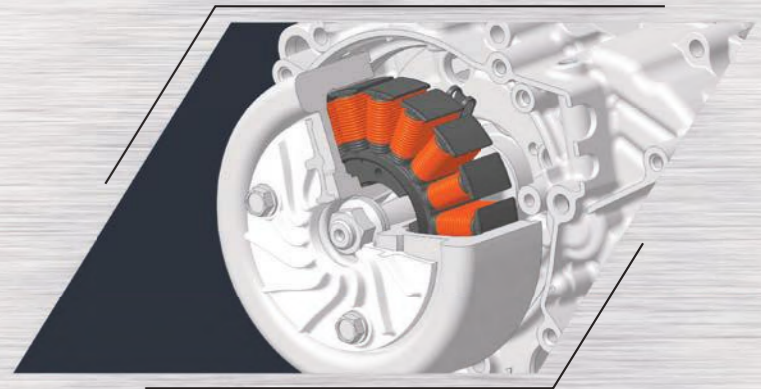

### **SIDE STAND ENGINE CUT-OFF**

Adds to the safety of the rider, it cuts off the ignition if the vehicle is put in gear when the side stand is engaged.



### **FRICITION REDUCTION**

The piston cooling jet reduces friction and maintains optimum engine temperature. The offset cylinder and rocker roller arm further reduces the frictional losses in the engine.

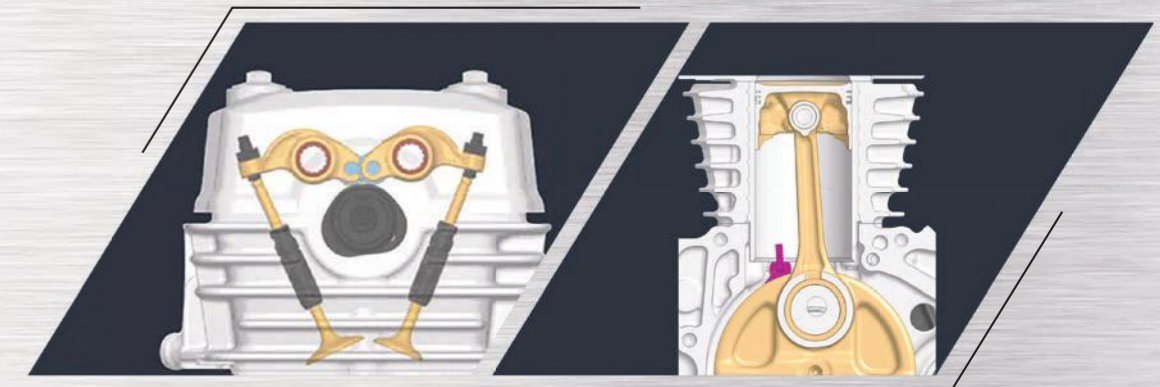



### FULL DIGITAL METER

Always stay updated with the full digital meter which displays real-time mileage, average mileage, distance to empty, service due indicator, gear position indicator & eco indicator. It also includes the side stand indicator with engine cut-off that adds to the safety of the rider, indicating when the stand is down.



### WIDER REAR TYRE

SP125 comes with wider rear tyre, which gives it better traction and grip to ensure better braking.

ADVANCED  
**STYLE**



**DYNAMIC TANK DESIGN  
WITH EDGY GRAPHICS**

A definite head-turner, the muscular fuel tank design, with new edgy graphics, makes it very appealing.

**SHARP LED DC HEADLAMP**

A sure shot style statement, the sharp LED DC headlamp gives consistent illumination while riding irrespective of the speed and riding conditions.





ADVANCED  
**COMFORT &  
CONVENIENCE**

### INTEGRATED HEADLAMP BEAM & PASSING SWITCH

Integrated smart single switch for  
passing signal and low/high beam.



### ENGINE START/STOP SWITCH

Start and stop your bike with just the flick of a switch  
anytime, anywhere. Enjoy enhanced convenience.

### 5-SPEED TRANSMISSION

Enhance the smooth yet thrilling ride  
experience with 5-speed transmission.

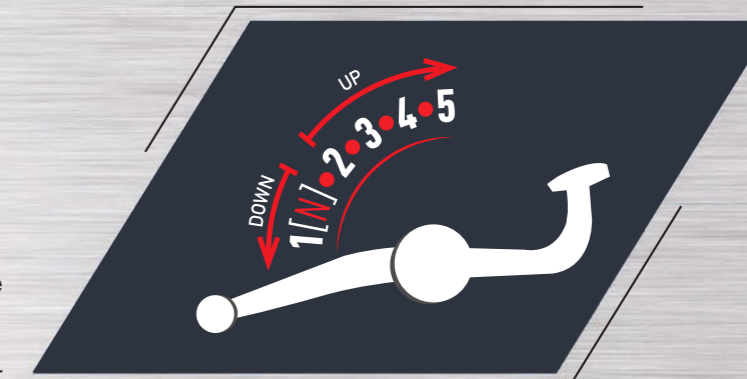



### SPORTY SPLIT ALLOY WHEELS

A split second is all you'll need to make your presence felt with the distinctive 5-spoke split alloy wheels.



### BOLD REAR STANCE WITH TAIL LAMP

The bold rear seamlessly integrates the tail lamp with the body enhancing the design statement.



### PREMIUM CHROME MUFFLER COVER

The stylish chrome muffer enhances the sporty looks.





### 3 + 7 YEARS WARRANTY PACKAGE

\*Complete peace of mind with 10 years warranty package, comprising 3 years standard and 7 years optional service warranty.

### 5-STEP ADJUSTABLE REAR SUSPENSION

It makes your ride comfortable across all road conditions.



### CBS WITH EQUALIZER

The combi-brake system with equalizer reduces braking distance. So that you can ride with full confidence.

### SEAL CHAIN

The seal chain is low on maintenance and high on durability and provides a hassle-free riding experience.

